



Vertical Platform Lift

Installation
Guide

Table of Contents

Disclaimers and Important Information	3
Prepare Your Tool Bag	7
Installing your Vertical Platform Lift	9
Step 1: Verify Job Requirements	9
Job Site Preparation	10
Step 2: Inspect the Crate	10
Step 3: Position the Platform Tower	11
Step 4: Remove the Shipping Blocks and Fasteners	11
Step 5: Attach the Car Sling to the Tower	12
Step 6: Secure the Travel Cable and the Underpan Cable	13
Step 7: Lift the Car Sling and Tighten Bolts	13
Step 8: Install the Platform Floor	13
Step 9: Connect the Batteries	14
Step 10: Batteries are Wired	15
Step 11: Startup Safety Conditions	15
Step 12: Run the Platform and Verify Function	16
Step 13: Attach the Exterior Wall	16
Step 14: Final Placement of the Tower	17
Step 15: Level the Tower	17
Step 16: Anchor the Platform to the Concrete Slab	18
Step 17: Set the Upper and Lower Landing Switches	19
Step 18: Install and Wire Call Stations	19
Step 19: Install and Wire the Upper Landing Gate	20
Step 20: Adjust the Interlock	21
Step 21: Attach Folding Ramp Control Arm and Ramp	22
Step 22: Install Facade Panel	22
Step 23: Attach COP into the Interior Guard Panel	23
Step 24: Attach the Underpan Under the Platform	23
Step 25: Attach All Stickers / Labels	24
Step 26: Instruct the Customer on Safe Operation of the Lift	24

Extended Tower Installation Guide	25
Step 1: Remove Drive Motor	26
Step 2: Position Lower Tower and Install Back Panel	27
Step 3: Mount and Fasten Upper Tower	28
Step 4: Install Upper Back Panel	29
Step 5: Connect Limit Switch Support	30
Step 6: Install Acme Screw Rod	31
Step 7: Prep the Drive Motor	33
Step 8: Remount the Motor Drive	34
Step 9: Install Bungee Cord	35
Step 10a: Install Batteries and Wire Drive Motor	36
Step 10b: Wire AC Drive Motor Configuration	37
Step 11: Mount Front Panel Support Bars	38
Step 12: Install Front Panels	39
Step 13: Mount and Fasten Top Cover	40

Disclaimers and Important Information

Shall not be held responsible or liable for any personal injury or property damage caused by or resulting from inappropriate operation of original product or of a product that has been modified or altered from the original Vertical Platform Lift (VPL) design. No person or company is authorized to change the VPL design without authorization and the express written consent.

Important

Do not throw away, destroy, or lose this installation guide. The instructions included in this guide must be followed to prevent product malfunction, property damage, injury, or death to the user or other people. Incorrect operation due to ignoring instructions found in this guide can cause harm, damage, injury or death. A summary of safety precautions is found below.

Warning

Read all instructions contained in this installation guide before installing the VPL. It is highly recommended to observe and adhere to all governing codes and ordinances in the job site locale. This includes ensuring all work and materials comply and conform with all authorities having jurisdictions. Proper installation is the responsibility of the installer and failure to follow all instructions renders the Limited Warranty null and void.

Safety Precautions

Safety of personnel is the primary concern during all procedures. Before beginning installation, read and understand the installation guide and containing procedures carefully to ensure correct and safe installation. Use the appropriate tools and accessories during installation. Plan your work and do not work alone, if possible. Know how to obtain emergency medical and fire fighting assistance.

Be sure to follow all the precautions on the next page as they are important for ensuring safety. This installation guide classifies the safety precautions into **DANGER, WARNING, CAUTION** and **NOTE**.

⚠ DANGER

Indicates an imminently hazardous situation which, if not avoided, will result in death or serious injury.

⚠ WARNING

Failure to follow any of WARNING is likely to result in such grave consequences as death or serious injury.

⚠ CAUTION

Failure to follow any of CAUTION may in some cases result in grave consequences.

⚠ NOTE

Provides information such as reminders and guidelines and do not fit into the preceding text.

Important for the Installer

The VPL shall be installed and serviced by an authorized dealer only. The authorized dealer should refer to this guide for installation and servicing. For maintenance, please refer to the Owner's Manual.

Please carefully read and follow the instructions found in this guide **BEFORE** installing and/or operating the VPL. Improper installation, adjustment, service, use or maintenance can cause personal injury or property damage. If you have any problems or need assistance please contact your dealer immediately.

Codes and Regulations

The VPL has been designed to meet CSA B613/B355 and ASME 18.1 standards. Code requirements and standards for vertical platform lifts vary depending on location and region. It is the installer's responsibility to contact their local code enforcement office and determine all of the regulations they are subject to. You must do this before installing the VPL.

Site Requirements

The VPL must only be installed on an approved pad or floor that has adequate drainage and meets local codes, standards and regulations. In addition, there must be adequate lighting and sufficient headroom above the lift. Please refer to and verify with the Technical Drawings before beginning the install.

Electrical Requirements

The VPL requires a 110VAC-20 AMP or 110VAC-15 AMP grounded electrical circuit and a GFCI protected circuit. Depending on local codes and regulations, this connection may need to be routed in electrical conduit and hard-wired.



WARNING

DO NOT OPERATE OR RIDE ON THE LIFT UNTIL IT HAS BEEN ANCHORED TO AN APPROVED PAD OR FLOOR.

Installation Safety Instructions



WARNING

To reduce the risk of fire, electric shock, personal injuries, and/or death, obey the following precautions:

- Never exceed the maximum rated lift capacity.
- Never use the VPL to lift freight or other materials than intended by design.
- Read and understand the installation guide prior to installing the VPL.
- Wear appropriate safety protection equipment for your head, eyes, hands and feet during all phases of the installation.
- Use extreme caution when lifting components into position to avoid personal injury and damage to the equipment.
- Keep panels and protective coverings in place to avoid potentially fatal injury.
- Disconnect power from the unit before performing any electrical or mechanical service operations.

- Never bypass sensor switches which prevent accidental start up when protective panels are removed.
- Be aware of the location of others in the work zone.
- Do not wear jewelry or loose clothing.
- Use only recommended anchor fasteners.
- Lock the wheels of any mobility device riding on the platform.
- Check and verify for applicable local codes and regulations.

 **NOTE**

Failure to comply the these Installation Safety Instructions could render the Limited Warranty null and void. If you have any question or concerns that are not covered in this installation guide, please contact your dealer immediately.

Prepare Your Tool Bag

Electrical Tools



Tester - AC/DC Clamp On Power Meter
(100 A dc Min)



Impact Driver - 1/4" Hex Drive Impact Driver



Drill - 1/2" Max Diam Drill with Impact
Function to Drill Concrete

Screwdrivers



Philips - (PH1) (PH2) (PH3)



Pozidriv - (PZ1) (PZ2)



Tork Bo



Slotted - (0.4 X 2.5) (0.6 X 3.5)
(0.8 X 4.0) (1 X 5.5)



Hexagon - (3MM) (3/32") (7/64")
(1/8") (9/64") (5/32") (3/16")
(7/32") (1/4")



Square - (#1) (#2) (#3)

1/4" Drive Hex Bits



Philips - (PH2) (PH3)



Square - (#2)



Extension



Adapter - 1/4" Hex Shank to 3/8"
socket Square drive

Ratchet



1/4" DR X 5" LONG



1/2" DR X 8" LONG



3/8" DR X 7" LONG

1/4" Drive Hex Socket



Hexagon - (13MM)

3/8" Drive Hex Socket



Hexagon - (7/16") (1/2") (9/16")

1/2" Drive Hex Deep Socket



Hexagon - (9/16") (3/4")

Drill Bits and Taps



Drill Bits - (9/64") (5/32") (13/64")
(17/64") (5/16") (3/8")



Concrete Drill Bit - (1/4") (3/8")



Taps - (8-32) (10-24) (1/4-20)
(5/16-18) (3/8-16)



Taps Holder - Tap Holder or Driver
Attachment for Drill



Punch Set - Kit

Dolly



Hand Tools



Hammer - 16 Oz. Min hammer



Pry Bar



Rubber Mallet - 16 Oz. Min Rubber
head mallet



Utility Knife - Snap Off Utility Knife
25mm Blade



Tape Measure - 16' Min



Bubble Level - 48" Beam Aluminum
Bubble Level



Plumb Bob - 8oz Brass Plumb Bob

Zip Ties - (12")

Pliers



Long Nose - 6"



Stripper - #10-22 AWG



Crimper - #10-22 AWG (insulated and
non-insulated terminals)



Fuse Puller



Retaining Ring - 8" Steel Retaining
Ring Pliers

Installing the Vertical Platform Lift

Step 1: Verify the job-site requirements.

Upper landing side railings, without openings. To be installed after the lifting platform is in place. They must be able to hold the landing gate assembly.

Runway must be smooth and extend 12" (help free) for 24" (with help) minimum on each side of landing gate. Otherwise, extend on all available area.

Pit lighting, flush mount (by electrician)

Pit lighting switch (by electrician)

1. Provide one GFI 120VC 15A outlet close to the back of tower only if a minimum of 24" access way is available, otherwise coordinate with lift installer.

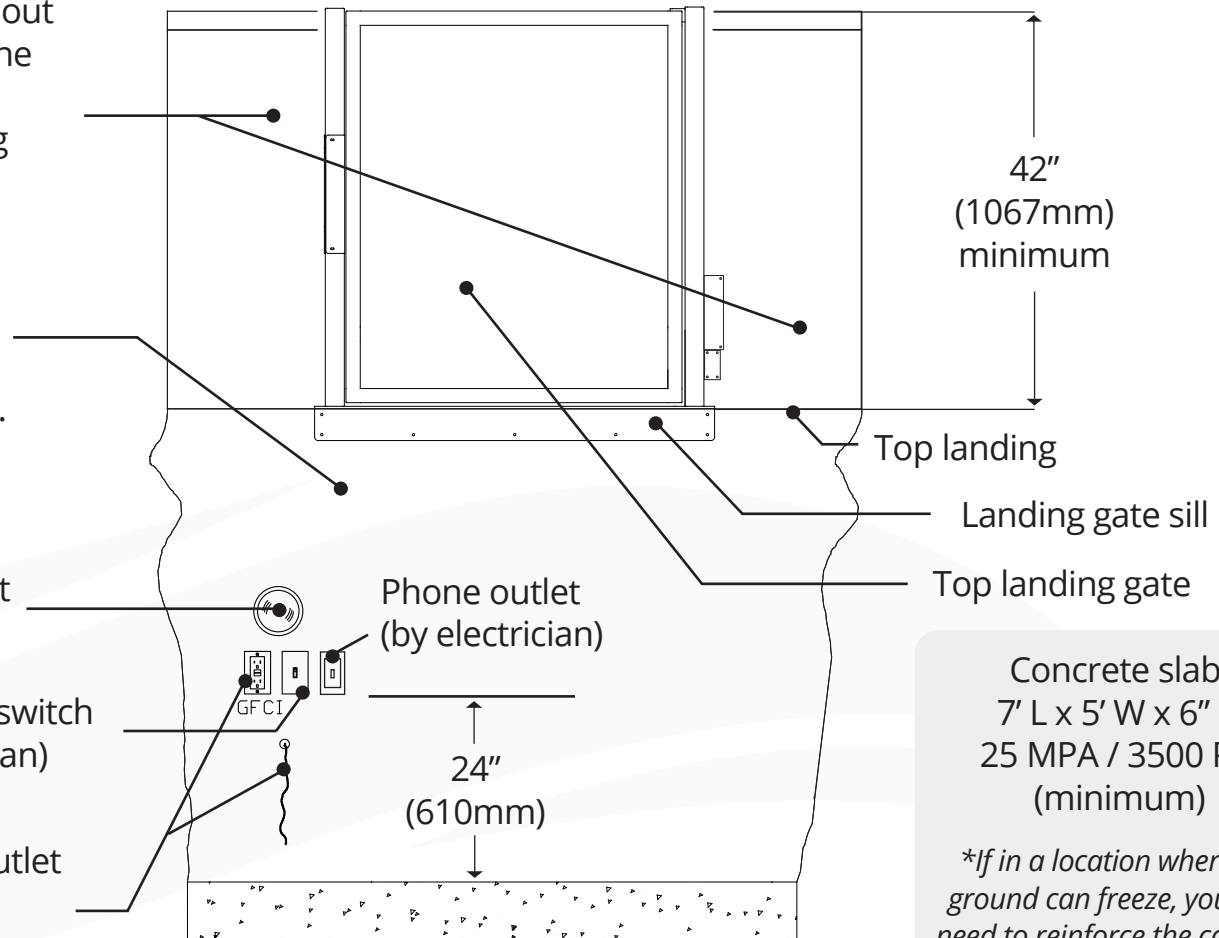

Concrete slab:
7' L x 5' W x 6" D
25 MPA / 3500 PSI
(minimum)

**If in a location where the ground can freeze, you may need to reinforce the concrete slab. Please refer to the technical drawings.*

Job Site Preparation

What You'll Need:

- **Electrical:** 120v/20a outlet (do not connect supply through the GFCI outlet)
- Concrete slab 5 x 7 x 5"
- Protection wall / flush – smooth / no pinch points



Step 2: Inspect the crate

- A. Look for damages
- B. Open box and make sure you have all parts

Parts Included:

- 2 U1 batteries (if DC unit)
- 1 box: folding ramp arm, bolts, touch up paint, labels, guides, bolts
- 1 installation kit (box)
- Folding ramp, 2 guard-panels, floor, under pan, top cover, car sling, top gate / interlocks / call stations (if applicable)



Standard 64" model



97 x 49 x 49
inches
1,000 lbs

Step 3: Position the platform tower

- A. Bring the tower on the concrete slab with a dolly



If you have an extended VPL model please refer to the **Extended VPL Tower Guide**

- B. Raise the tower and place it in its approximate position. (**PRO TIP:** you can also use steel bars as rollers, a pry-bar and mallet, or walk the tower corner to move easily the platform on the concrete slab See image Step #15)
- C. **DO NOT ANCHOR THE TOWER YET*****

Step 4: Remove the shipping blocks and fasteners

▲ Remove the tower front panel cover to gain access to the inside of the tower.

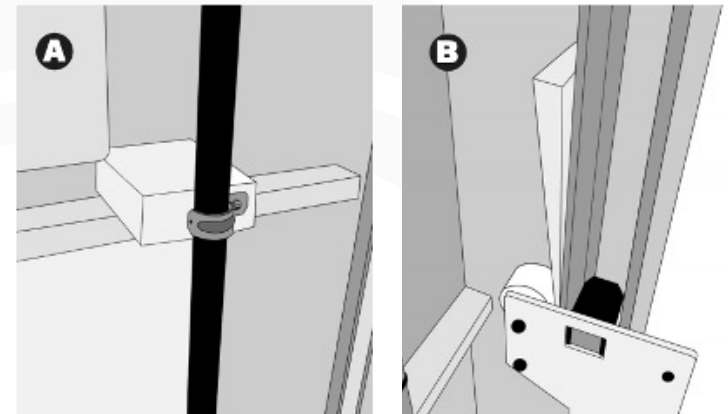

Step 5: Attach the car sling to the tower

- A. Bolts are already on the car sling (unscrew and screw)
- B. **IMPORTANT:** Use the same bolt combination that is already on car sling
- C. **DO NOT tighten the bolts yet.*****

4.1 MOUNT CAB SUPPORT LEGS TO CAR SLING

MATERIALS

Hardware is already attached to the Upright Support Legs, keep the same bolt order and configuration when installing.

INSTALL

1. Align the Upright Support Legs with the Car Sling.
2. Align the Car Sling mounting holes with those of the Upright Support Legs.
3. Using the same bolt configuration, attach together the Upright Support Legs & Folding Ramp Mount with the Car Sling.

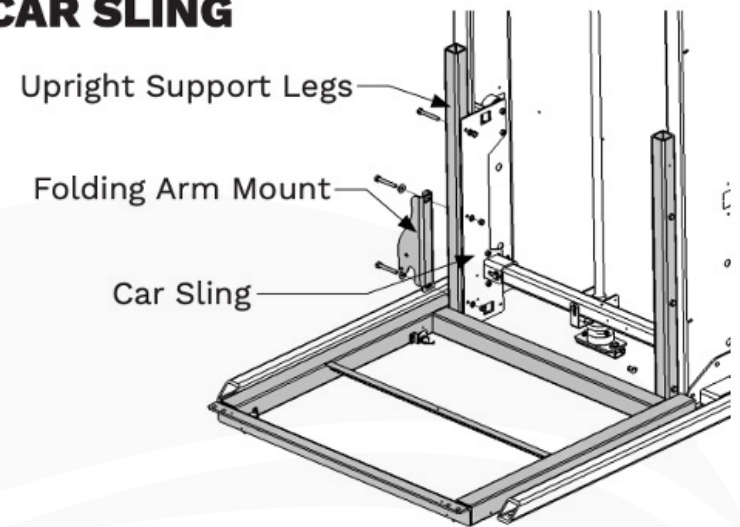

Step 6: Secure the travel cable and the under-pan cable

- A. Fix the travel cable on the side of the car sling (as shown below)



- B. Fix the under-pan wire in the corner of the roller arm and secure with a zip-tie.

Step 7. Lift the car sling slightly off the ground with the hand crank, and then tighten the bolts

Step 8: Install the platform floor centered on the car sling

Step 9: Connect the batteries (If you have an AC model, jump to Step 13)

- A. Wiring scheme available by scanning QR code

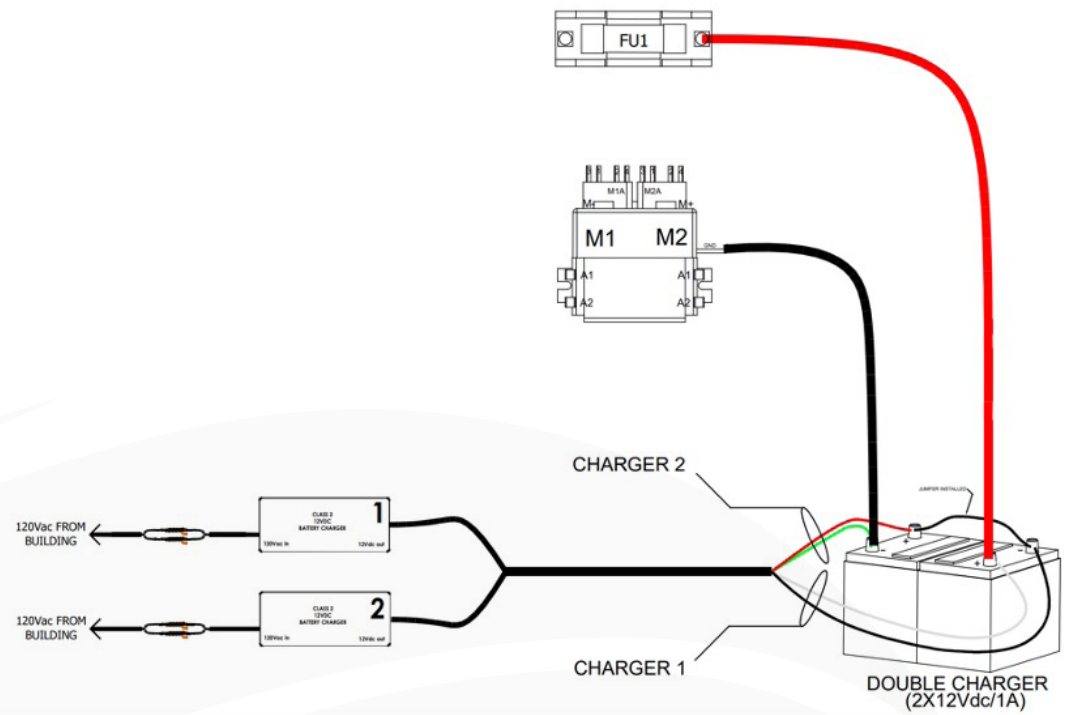

Step 10: Once the batteries are wired

- A. Plug in the platform power plug, make sure all emergency stops are pulled (COP & side of tower), make sure call stations and COP keys are turned on and the platform should now move up and down.

Step 11: If the platform does not move: Perform the startup (safety) conditions

- A. Follow the startup condition points, and when the voltage drops, that's where your problem is.
- B. QR code to access the troubleshooting guide (side of the tower).

Time Stamp for Checking the Safety Pan Circuit

0:10	Tools Required	5:48	P5 F.O. Switch Connections
0:20	P1 Accessing Internal Components	7:21	P6 Emergency Stop
2:35	P2 Testing Main Fuse	9:35	P7 i1 Jumper Voltage
4:00	P3 Testing the Breaker	10:18	P8 Gate Interlock and Usage
5:09	P4 Testing Limit Switch Connections	11:56	P9 Safety Pan Circuit

Step 12: Run the platform a few inches up then down to verify functionality

Step 13: Attach exterior wall

- A. Tighten with impact gun and torque after with a hand wrench.
- B. Follow installation guide for more details

4.4 MOUNT EXTERIOR GUARD PANEL

MATERIALS

- 4 Hex Bolts (3/8" X 1 1/2")
- 18 Flat Washers (3/8")
- 4 Split Lock Washers (1/4")
- 4 Nylon Nuts (3/8")

INSTALL

1. Using 1 Hex Bolt (3/8" X 1 1/2"), 4 Flat Washers (3/8"), 1 Split Lock Washer (1/4") and 1 Nylon Nut (3/8") attach the Exterior Guard Panel at the Exterior Bolt Insertion Point.
2. Using 1 Hex Bolt (3/8" X 1 1/2"), 3 Flat Washers (3/8"), 1 Split Lock Washer (1/4") and 1 Nylon Nut (3/8") attach the Exterior Guard Panel at the Interior Bolt Insertion Point.
3. Repeat steps 1 & 2 on the other side of the Exterior Guard Panel.

▲ CAUTION

Keep the same hardware configuration as shown in the image.

▲ IMPORTANT

For anti-corrosion models, use 3 flat washers on top and 4 below.

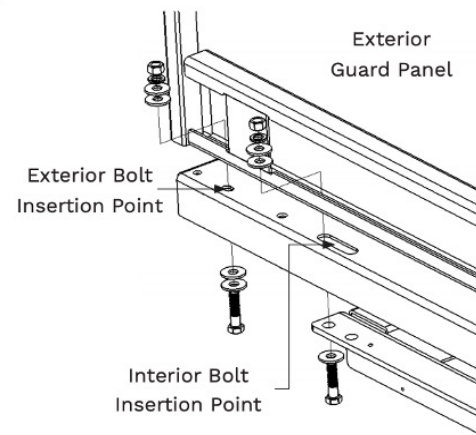

Step 14: Final placement of the tower

- A. Refer to local codes to determine the gap space between the end of the platform and the edge of the top landing. (Standardly will be within $\frac{3}{4}$ of an inch from the landing wall)

5.3 POSITION THE LIFT

INSTALL

1. Lay 1-inch steel rods into position.
2. Roll the lift onto steel rods **A**.
3. Using the pry bar, gently maneuver the lift to the proper orientation for the cab type.
4. Slide the lift into position using the steel rods as rollers. Align the lift with Upper Landing Gate **B**.

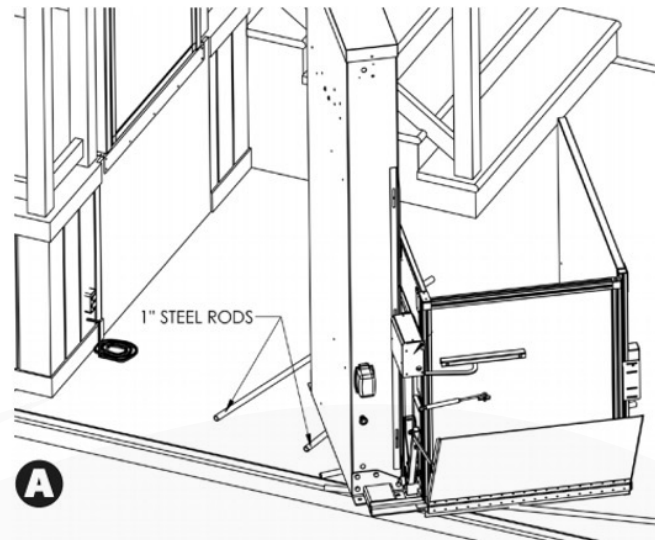

Step 15: Level the tower

- A. Use a level and shims to level the tower (we supply stainless steel shims in the installation kit)
- B. Check the platform, both legs and both sides of the tower to ensure it is leveled.
- C. After leveling double check the platform gap (running clearance) to be sure it has not moved. Adjust if necessary.

Step 16: Anchor the platform to the concrete slab

- A. Drill the 6 holes with a hammer-drill.
- B. Place the lag bolts in the holes and hammer them down, but DO NOT tighten them yet (Use the supplied Cobra concrete anchors)
- C. Perform a final verification that the platform gap is the same and that the tower is still level.
- D. Tighten the 6 lag bolts in a star pattern.

5.7 ANCHOR THE LIFT TO THE PAD OR FLOOR

MATERIALS

- 3/8" Concrete Drill Bit
- 6 Anchor Bolts
- Aluminum Shims
- Pry Bar

INSTALL

1. Position the lift into its final location.
2. Verify that the lift is positioned properly and according to the site's drawing plan. Verify that the lift is level and shim if necessary.
3. Drill 6 holes into the floor/pad, using the lift's anchor points as a template.
4. Verify that the drilled holes are proper size to accept the Floor Anchors.
5. Drive anchors into the foundation.
6. Secure the lift in place by tightening the Floor Anchor bolts to 25ft-lb

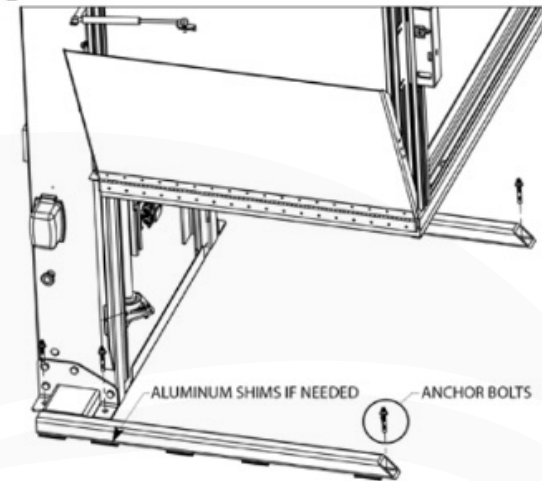

⚠ WARNING

Dust or debris may have settled into the freshly drilled holes. Clean out the holes to ensure the Floor Anchors set correctly.

⚠ CAUTION

Verify the maximum landing clearance between the platform and the protection wall. In Canada - HERCULES DC B613(RESIDENTIAL) : maximum clearance of 1" and HERCULES DC B355 (COMMERCIAL) : maximum clearance of 1/2" . In the USA shall not be less than 0.375" (10mm) nor more than 0.75" (20mm)

Step 17: Set the upper and lower landing switches

- A. Platform must stop on the limit switches for both top and bottom landing. That's what unlock the gates / interlocks.

Step 18: Install and wire call stations

- A. Plug into the 3-pin quick connector (see right for the platform panel box)



- B. pass the wires inside the conductors. This protects the wires and avoid potential shorts.



5.9 INSTALL LOWER LANDING CALL STATION

MATERIALS

- Lower Landing Call Station
- 4 Tapcons 1/4 inch X 1 3/4 inch (if applicable)

INSTALL

1. Wire according to the provided Electrical Diagram(s).
2. Mount or fix the Call Station to the floor or pad with 4 Tapcons when applicable.
3. The Lower Landing Call Station wires must be protected and/or anchored to the ground or buried.



Surface Mounted



Wall Mounted



Post Mounted

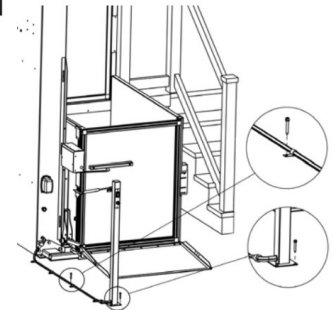

⚠ DANGER

In the event that the Lower Landing requires a custom door or the door is being provided by an installer/client, Remove the Jumper Cable (CN16, 15-16) on the Cab COP 16-PIN Terminal Block (**NOT ON THE TOWER CONTROLLER**).

Step 19: Install and wire the upper landing gate

- A. Align the gate with the platform opening to avoid pinch points.
- B. Connect the gate & interlock wire quick connectors into the platform controller quick connectors.
- C. **TIP:** Run the wires in conduits to protect them and avoid potential issues in the future.
- D. Fix the supplied "L" brackets on each side of the gate to secure and stabilize the gate to ensure proper operation of the interlock.
(see image on the right)



Step 20: Adjust the interlock

- A. Both gate posts must be anchored and level.
- B. Once posts are steady and straight, adjust the latch to enter the dead center of the interlocks latching hole and tighten into place.
- C. Then, insert the latch inside the interlock until it locks.

***Note:** there are 2 micro-switches inside the interlock they both must be released non-activated) or the unit to run!

Step 21: Attach the folding ramp control arm and the ramp

- A. Then move platform to ensure it functions properly. Make any adjustments necessary.
- B. Be careful not to put weight on it while it is folding. It'll brake it.

Step 22: Install facade panel (tower front wall) and top cover

- A. Plug into the 3-pin quick connector (see right for the platform panel box)

5.12 REINSTALL FRONT PANEL AND TOP COVER

INSTALL

1. Place Front Panel and Top Cover into position. Be careful to **NOT** damage the Underpan Flat cable and the Interlock wire at the bottom when lowering the Front Panel.
2. Using 4 x Screws, fasten both the Front Panel and Top Cover.

▲ DANGER

Be careful to **NOT** damage the Underpan Flat cable and the interlock wire at the bottom when lowering the Front Panel.



Step 23: Attach COP into the interior guard panel

- A. Secure the travel cable to the interior panel with a zip-tie.
 - a. Pulling traveling cable towards the COP cover and zip-tie tightly.
 - b. Fit the rest of the traveling cable under the COP cover.

Step 24: Attach the under-pan under the platform

- A. Make sure each micro-switch is adjusted downward. (4x)
- B. The switches shall only click when under-pan is pushed up.

4.5 ATTACH SAFETY UNDERPAN

MATERIALS

- 4 Hex Bolts (1/4"-20 x 1 1/2")

INSTALL

Attach one side of the Safety Underpan using 2 Hex Bolts (1/4"-20 x 1 1/2"). Repeat this step on the other side of the Safety Underpan.

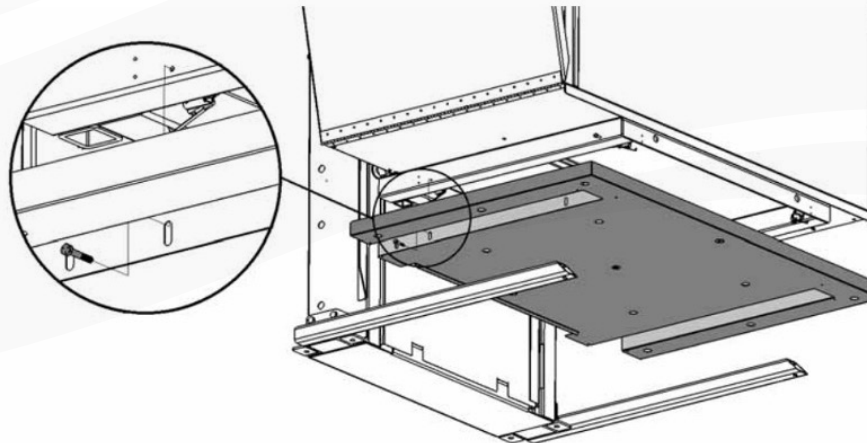

Step 25: Attach all stickers/labels in appropriate place

Step 26: Instruct the customer on safe operation of the lift

- A. Safe operations of the lift.
- B. Who/how to call for service and the information needed for service.
- C. Emergency lowering device.
- D. How to unlock gate interlock with the override key
- E. Beeping alarm = estop engaged
- F. Recommend to leave the unit 24" above the ground during winter to avoid it freezing to the ground
- G. Always let the power supply on otherwise you will dry the batteries.

Extended Tower Installation Guide

If you have an extended VPL model, please refer to this guide. Make sure to read this guide carefully to ensure correct installation.

For Residential and Commercial applications

Step 1: Remove Drive Motor

Procedure

Unmount the Drive Motor

Install

- A. Unfasten the 4 Hex Bolts, 4 Washers and 4 Spacers
- B. Remove the Drive Motor and set aside

IMPORTANT
ENSURE TO KEEP THE SAME BOLT
CONFIGURATION FOR REMOUNTING THE DRIVE
MOTOR IN STEP 8.

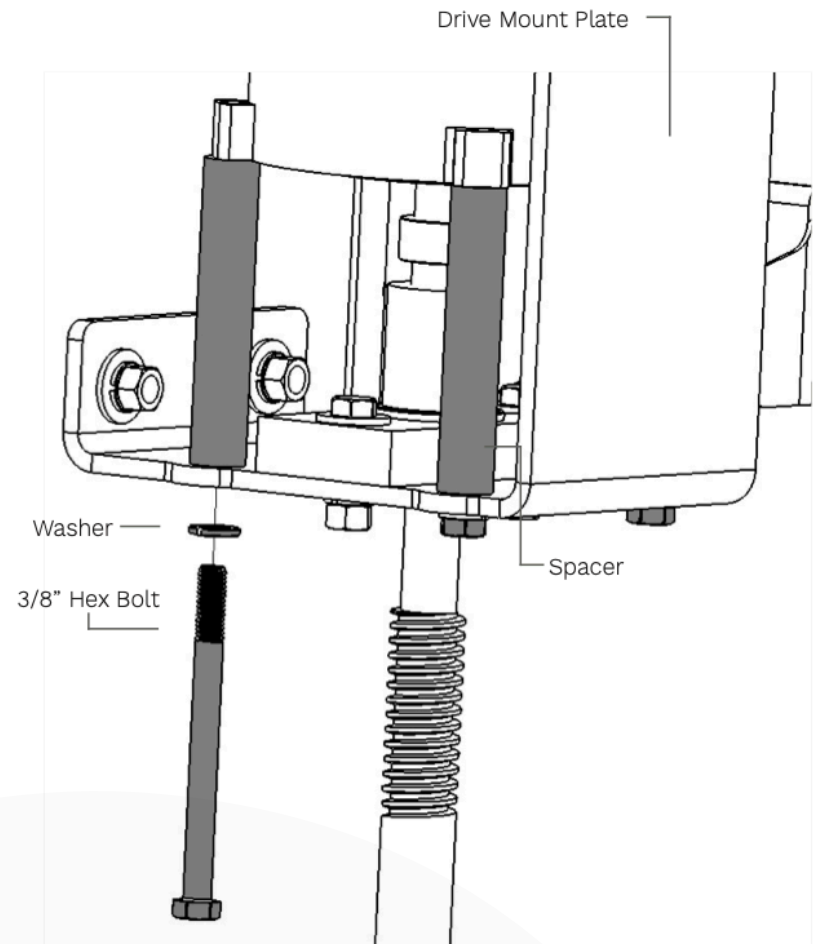

Step 2: Position Lower Tower and Install Back Panel

Materials

- Lower Back Panel
- Truss Phillips Screws

Procedure

Place the Lower Tower near to it's final position and install the Back Panel

Install

1. Slide the Lower Tower near it's final position. **Be sure to leave room behind the Lower Tower so that you can access it from the back.**
2. Align and fasten the Lower Tower Back Panel using Truss Phillips Screws (10/24 X 3/4").

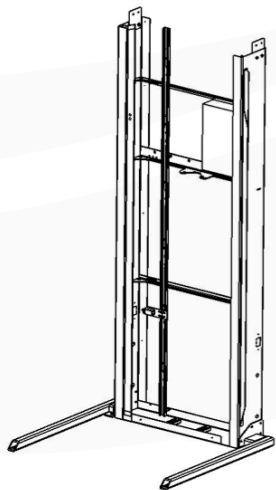

FIG 1. LOWER TOWER

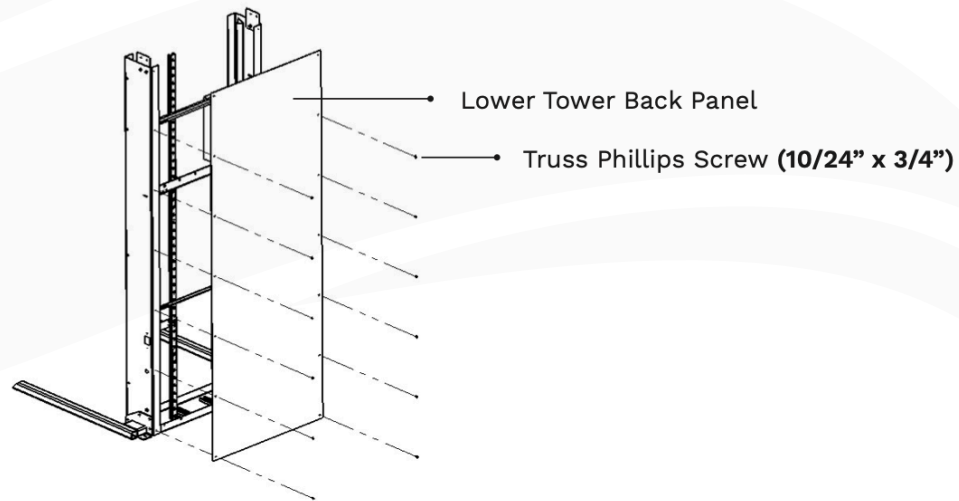

FIG 2. LOWER TOWER BACK PANEL

Step 3: Mount and Fasten Upper Tower

Materials

- Upper Tower
- 2 Hex Bolt (3/8 X 3/4")
- 4 Hex Bolts (5/16 X 1/2")
- Folding Ramp Cam Joint and Hardware

Procedure

Mount and fasten the Upper Tower on top of the Lower Tower.

Install

1. Align and slide the Upper Tower on top of the Lower Tower.
2. Fasten the Upper and Lower Tower together using 2 Hex Bolts (5/16 X 1/2") and 1 Hex Bolt (3/8 X 3/4") on each side of the Tower.
3. Install and fasten the Folding Ramp Cam Joint using 2 Hex Bolts (5/16 X 1"). Hardware is already attached to Angled Iron Bar.

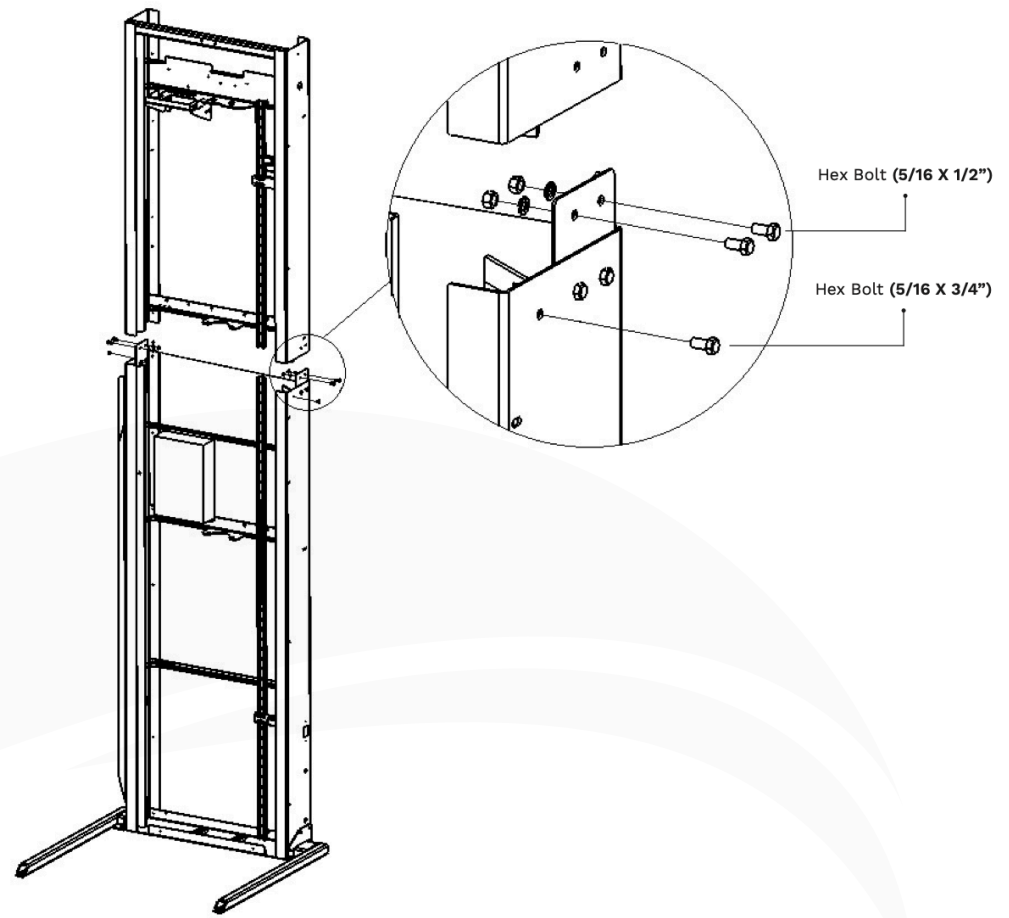

Step 4: Install Upper Back Panel

Install

1. Align and fasten the Upper Back Panel using Truss Phillips Screws (10/24 x 3/4").
2. Slide the **EXTENDED** Vertical Platform Lift into it's final position.

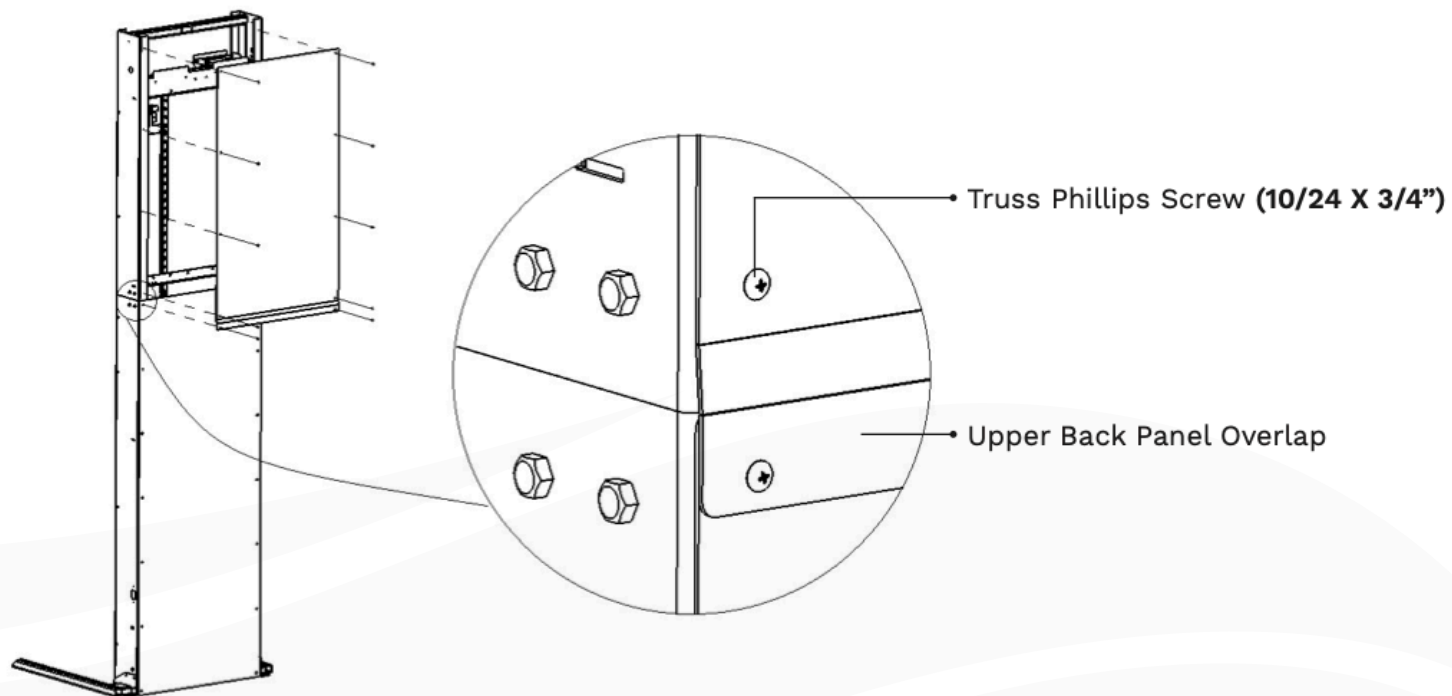

Step 5: Connect Limit Switch Support

Procedure

Fasten together the Upper and Lower Switch Support Rails.

Install

1. Connect and fasten the Upper and Lower Switch Support Rails using provided hardware and bracelet.
2. Loosen Upper Limit Switch Assembly and unroll the cable. Slide and fasten the Upper Limit Switch into position for later installation and calibration.

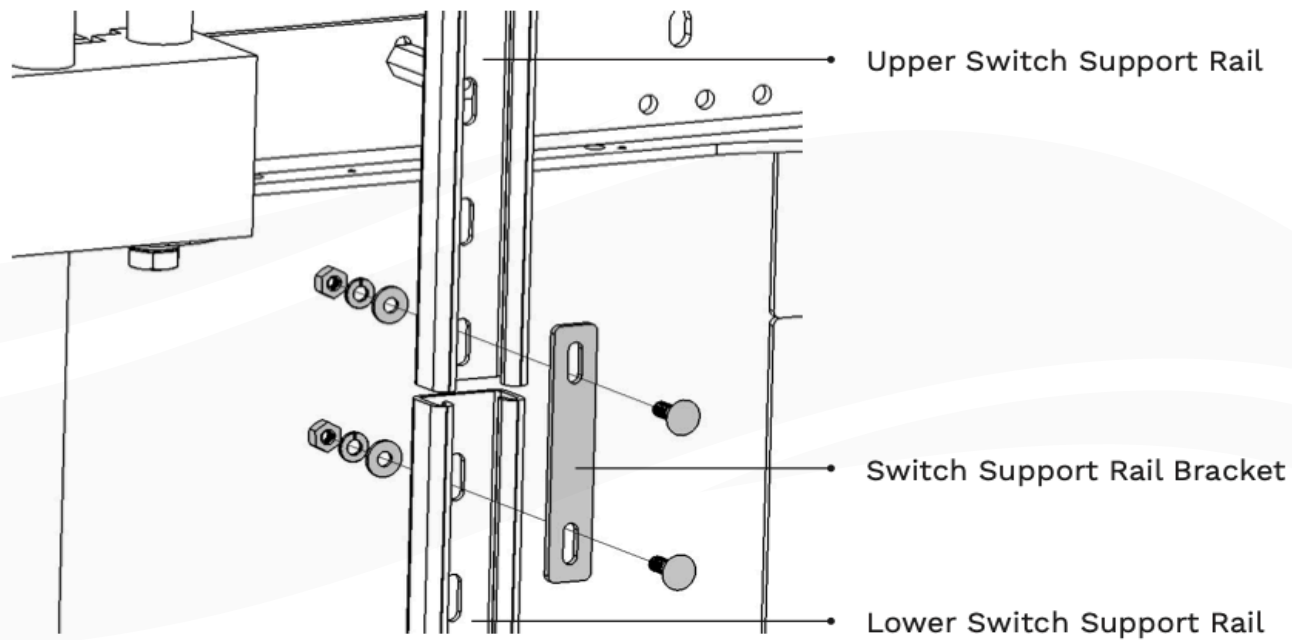

Step 6: Install Acme Screw Rod

CAUTION

USE TWO PEOPLE WHEN HANDLING AND INSTALLING THE ACME ROD. BE CAREFUL NOT TO BEND THE ACME ROD. ANY FLEXING OF THE ACME ROD WILL RENDER THE ROD UNUSABLE.

Procedure

Install and fasten the Acme Screw Rod.

Install

1. Place the Top Bearing into the Aluminum Base.
2. Position the Upper Slide Block to its uppermost position.
3. Using **TWO PEOPLE**, slide the Acme Screw Rod through the bottom of the Upper Slide Block Assembly.
DO NOT BEND OR ALLOW ANY FLEX OF THE ACME SCREW ROD.
4. Continue sliding the Acme Screw Rod through the bottom of the Aluminum Base and Bearing.
5. While holding the Acme Screw Rod, screw on the Top Coupler all the way down, until the Key Seats of the Top Coupler and Acme Screw Rod align. (It's OK if you have to "Back Screw" the Top Coupler to align the Key Seats).

Upper Slider Block Full Assembly

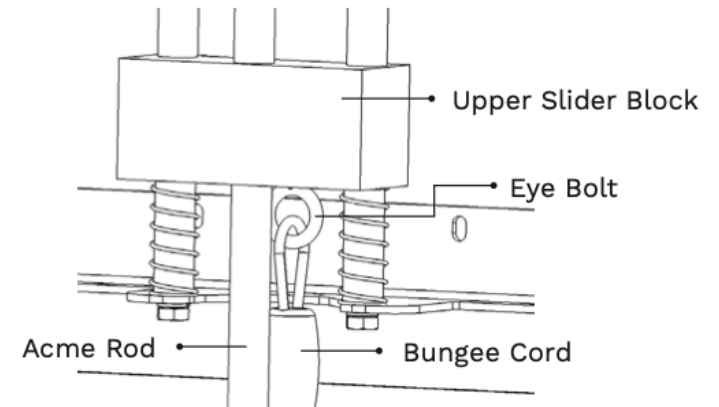

ACME ROD UPPER ASSEMBLY

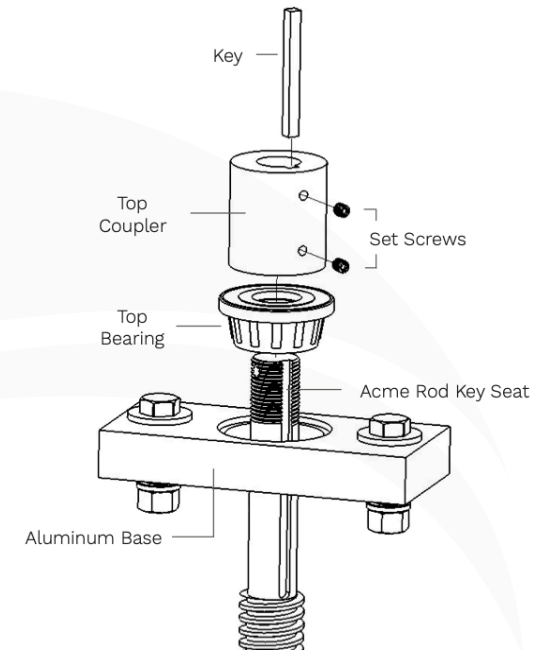

6. Thread the Acme Screw Rod

through the Plastic Acme Nut. **DO NOT BEND OR ALLOW ANY FLEX OF THE ACME SCREW ROD.**

7. Continue threading the Acme

Screw Rod through the Plastic Acme Nut, Brass Safety Nut, the Lower Slider Block and into the Lower Plastic Bearing.

8. Ensure the width between

the Bottom of the Plastic Acme Nut and the Top of the Brass Safety Nut is 9/16".

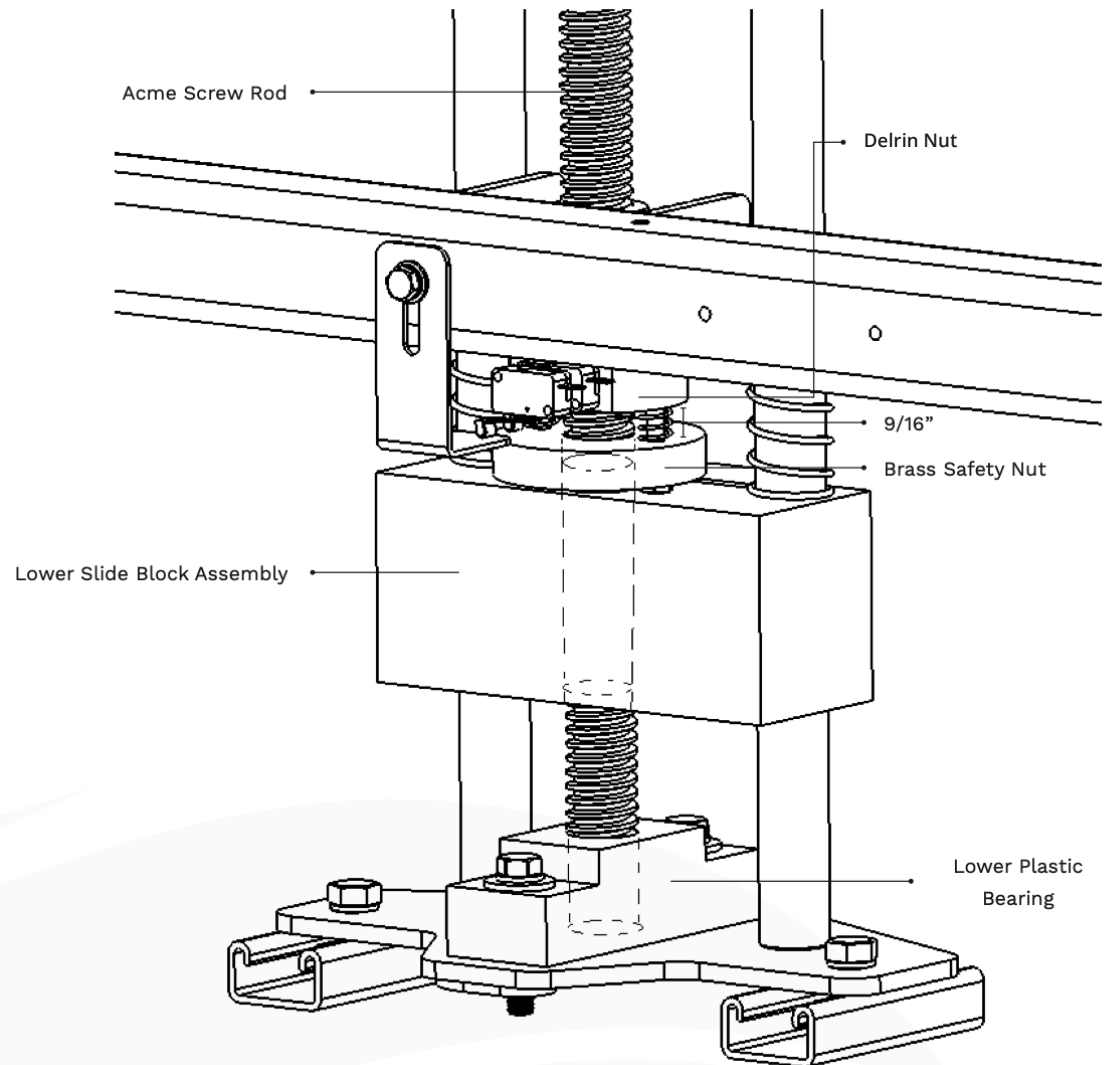

Step 7: Prep the Drive Motor

Procedure

Install and fasten the Drive Motor's Output Drive Shaft.

Install

1. Insert the Output Drive Shaft into the 90° Gearbox, keeping the Drive Shaft Key Seat aligned with the Acme Screw Rod Key.
2. Slide the Drive Shaft Collar above Drive Shaft Key Seat and fasten Set Screw.
3. Install the Retaining Ring before proceeding to the next step.

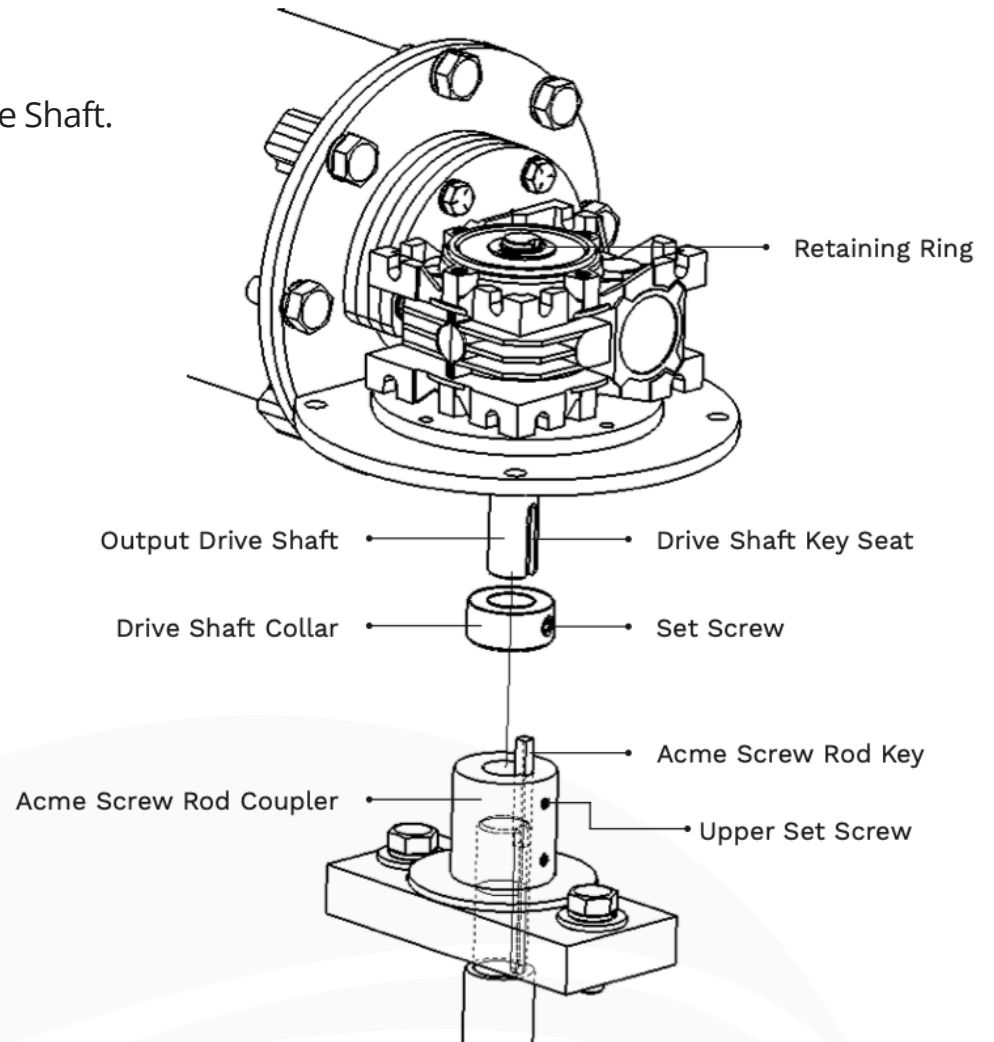

Step 8: Remount the Motor Drive

Procedure

Install and mount the Drive Motor.

Install

1. Align the Drive Shaft Key Seat and the Acme Screw Rod Key.
2. Slide Drive Motor onto the Acme Screw Rod.
3. Tighten the Upper Set Screw on the Acme Screw Rod Coupler.
4. Fasten the Drive Motor to the Drive Mount with the 4 Hex Bolts, 4 Washers and 4 Spacers.

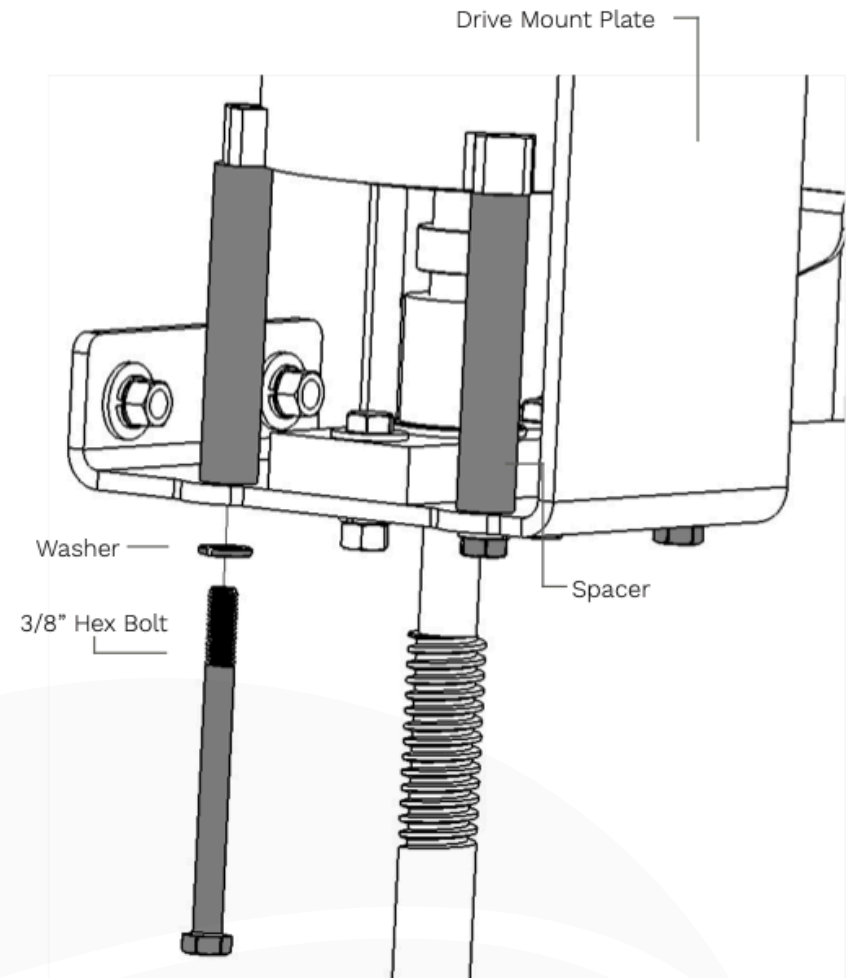

Step 9: Install Bungee Cord

Procedure

Install the Bungee Cord to the Upper and Lower Slider Block Assembly.

Install

1. Attach one side of the Bungee Cord Carabiner to the Eye Bolt on the Upper Acme Rod Slider Block Assembly.
2. Attach the other side of the Bungee Cord Carabiner to the Eye Bolt on the Lower Acme Rod Slider Block Assembly.

Upper Slider Block Assembly

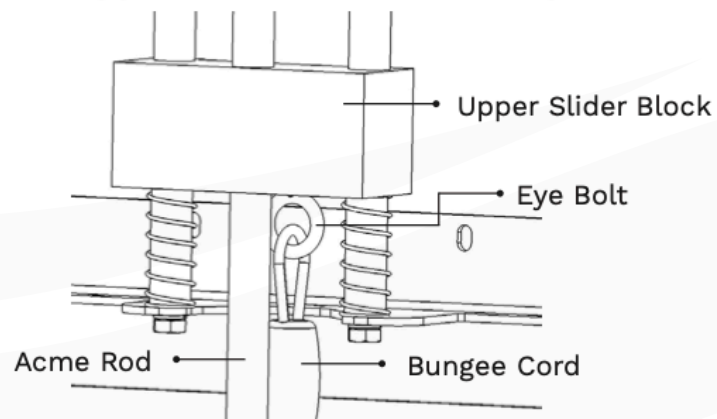

Lower Slider Block Assembly

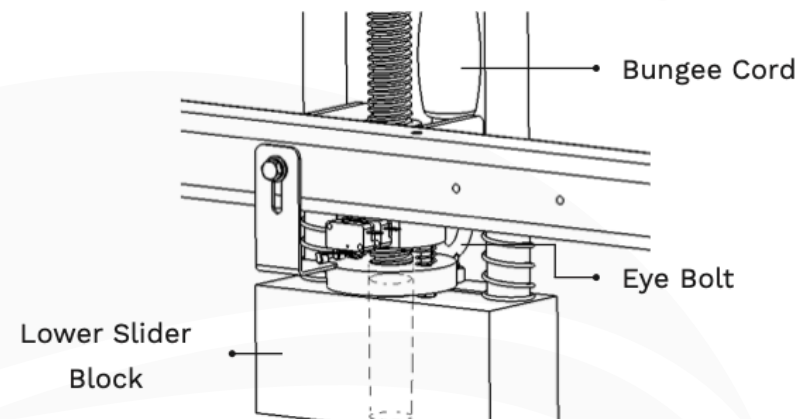

Step 10a: Install Batteries and Wire Drive Motor

Procedure

Connect Batteries and Drive Motor

NOTE

BATTERY INSTALLATION IS ONLY REQUIRED ON DC MODELS.

Install

1. Place batteries into the upper tower position.
2. Use the Electrical Diagram to make the proper wiring connections.

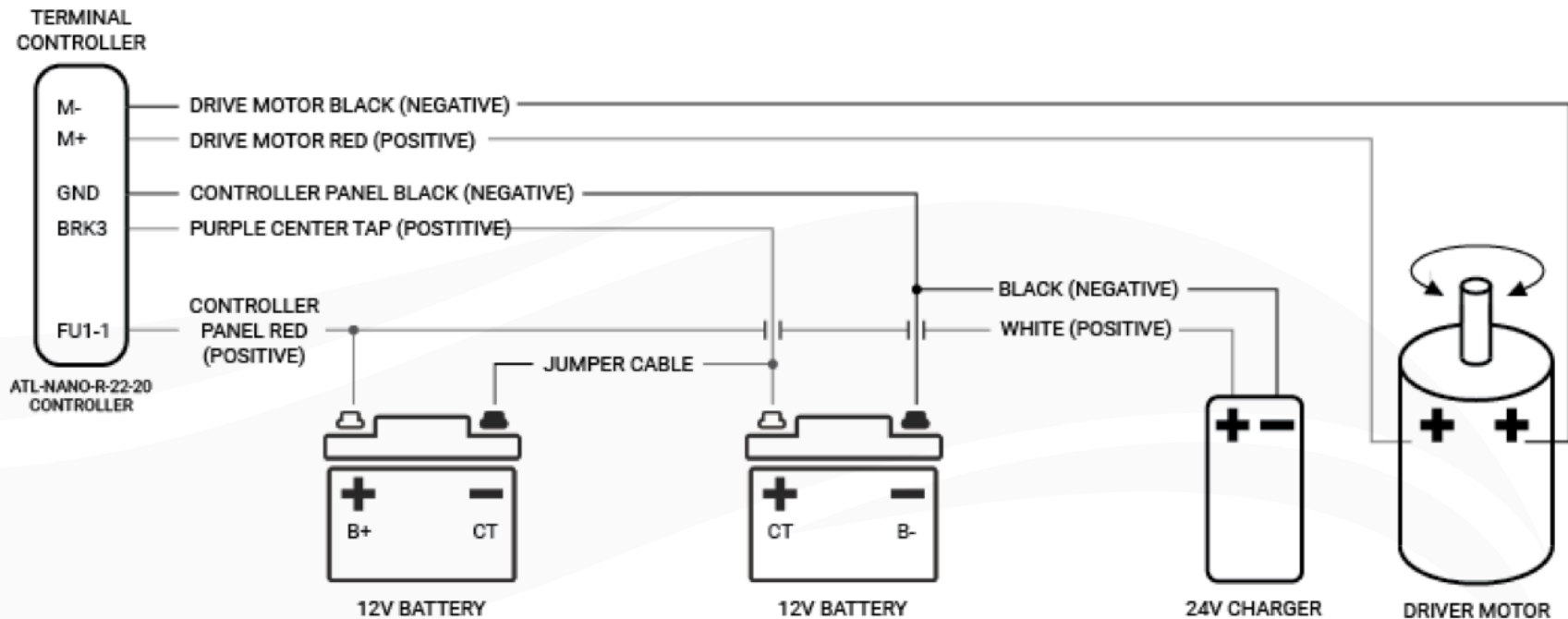

Step 10b: Wire AC Drive Motor Configuration

Procedure

Connect the Transformer and Drive Motor

NOTE

THIS INSTALLATION IS ONLY REQUIRED ON AC MODELS.

Install

1. Place batteries into the upper tower position.
2. Use the Electrical Diagram to make the proper wiring connections.

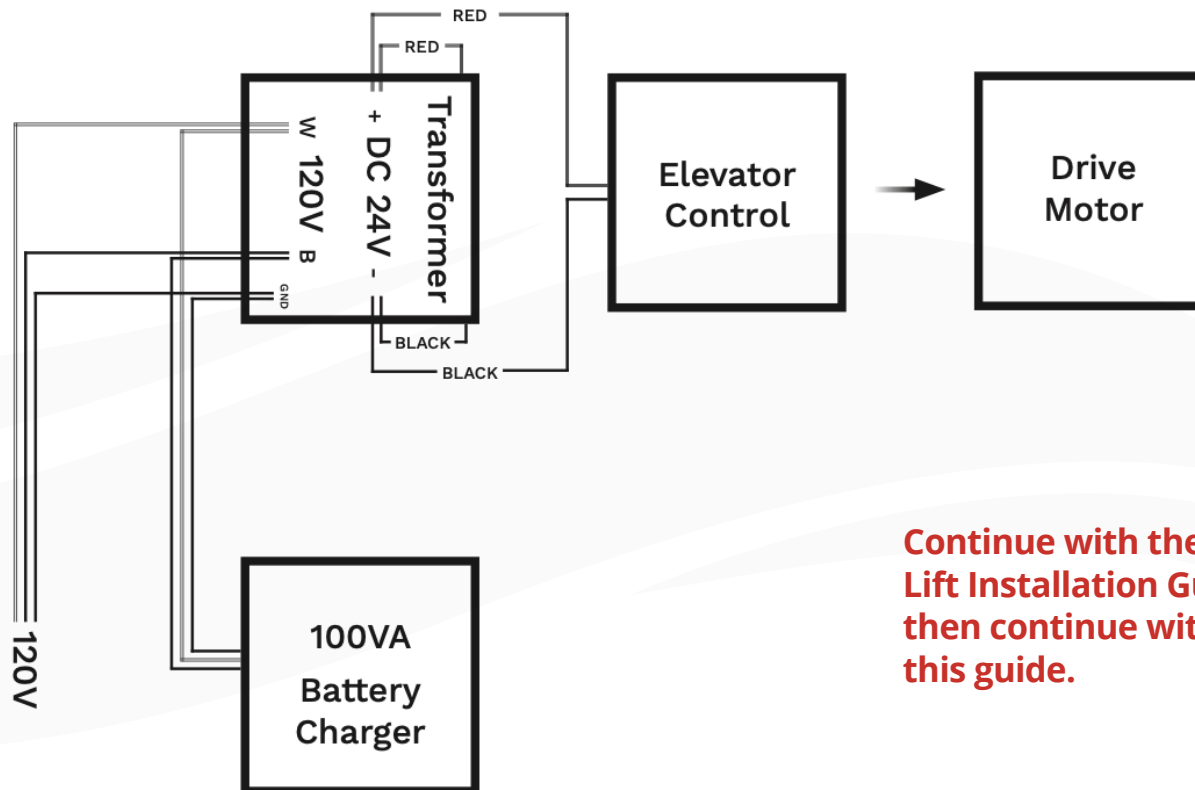

Continue with the Vertical Platform Lift Installation Guide until step 14, then continue with step 11 of this guide.

Step 11: Mount Front Panel Support Bars

Materials

- 4 Flat Head Mach. Screws 4 Hex Bolts (1/4-20 x 1-1/2")
- 4 Washers
- 4 Hex Nuts

Procedure

Install and Fasten the Front Panel Support Bars.

Install

1. Fasten the top of the Support Bars. Make sure that the bars are placed on top of the Upper Horizontal Bracing Bracing and fastened with proper bolt configuration.
2. Fasten the bottom of the two Support Bars. Ensure that the bars are placed behind the Lower Horizontal Bracing and fastened with proper bolt configuration.

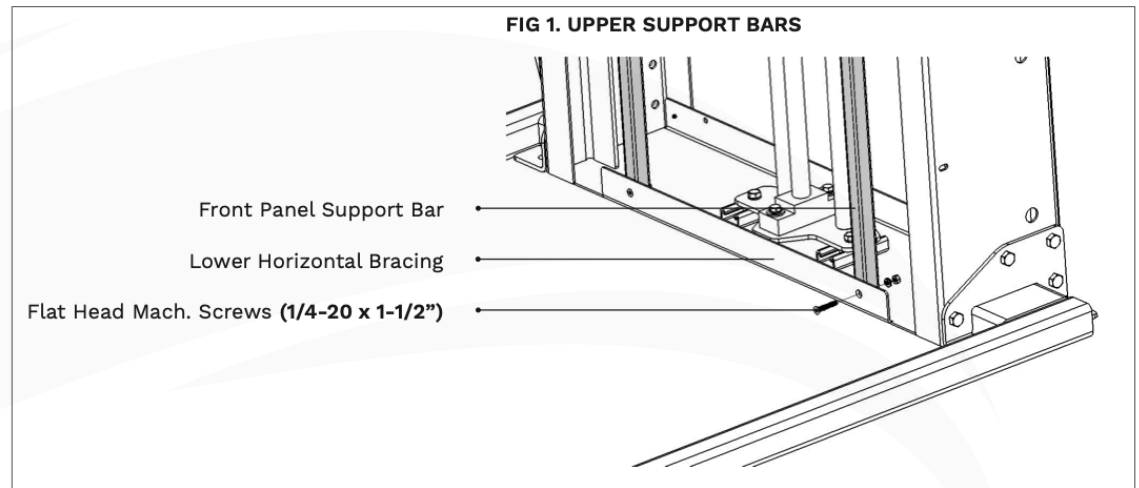
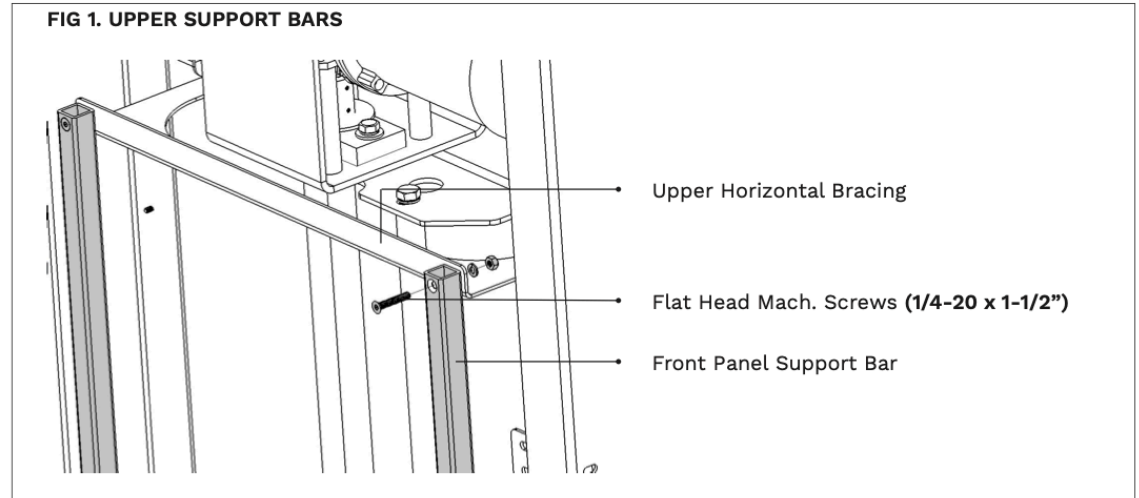

Step 12: Install Front Panels

Materials

- Lower and Upper Front Panels
- Truss Phillips Screws (10/24 x 3/4")

Procedure

Install and fasten Front Tower Panels.

Install

1. Align and slide the Lower Tower Front Panel into position. Fasten the panel using Truss Phillips Screws (10/24 X 3/4").
2. Align and fasten the Upper Tower Front Panel. Make sure the Upper Front Panel overlaps the Lower Front Panel. Fasten the panel using Truss Phillips Screws (10/24 X 3/4").

FIG 1. LOWER FRONT PANEL

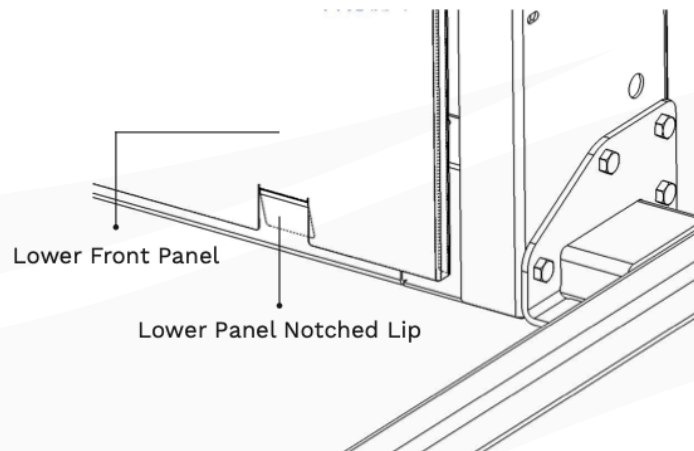
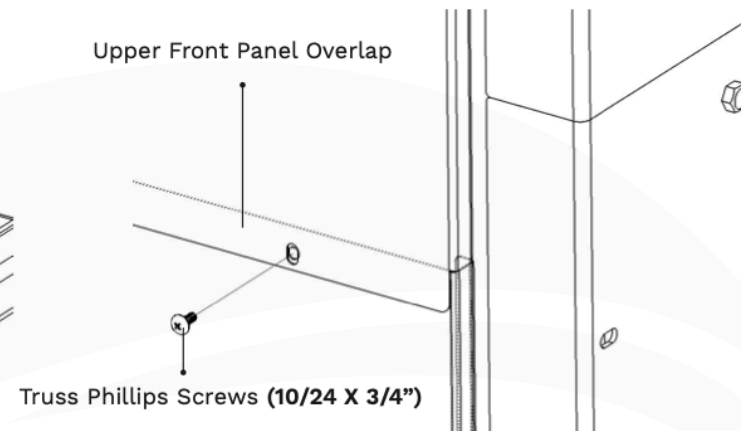

FIG 2. UPPER FRONT PANEL



WARNING
ENSURE THAT THE LOWER PANEL NOTCHED LIP SLIDES BEHIND THE LOWER HORIZONTAL BRACING.

Step 13: Mount and Fasten Top Cover

Materials

- 4 Truss Phillips Screws (1/4"-20 x 3/4")

Procedure

Place and fasten Top Cover

Install

Place the Top Cover on top of the Tower and fasten into place using 4 Truss Phillips Screws (1/4"-20 X 3/4").

